

# STAINLESS STEEL SIDE TILE FINISHING BRACKETS

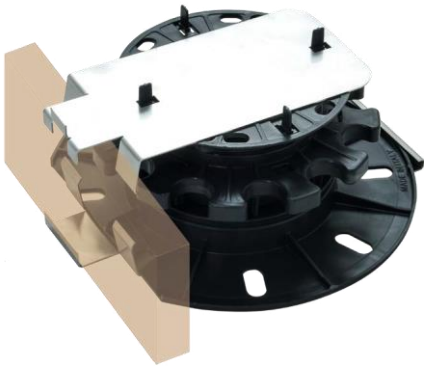

## INDEX

1. Data and Documentation
2. Use
3. Specifications

## 1. DATA AND DOCUMENTATION

Code	Description	Dimensions (mm)	Weight	Pkg. / Pallet
TER09-1146/C	Sub-base bracket for 10 mm side trim	-	0.106 kg/pc.	80 pcs. / - pcs.
TER09-1146/E	Bracket Plate for 10 mm Side Finishing	-	0.079 kg/pc.	80 pcs. / - pcs.
TER09-1146/D	20 mm Sub-Base Bracket for Side Finishing	-	0.107 kg/pc.	80 pcs. / - pcs.
TER09-1146/F	Bracket Plate for 20 mm Side Finishing	-	0.077 kg/pc.	80 pcs. / - pcs.

**MATERIAL** Made of stainless steel.

TER09-1146/C

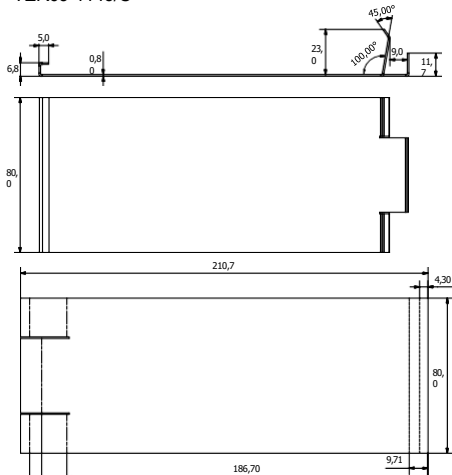

TER09-1146/E

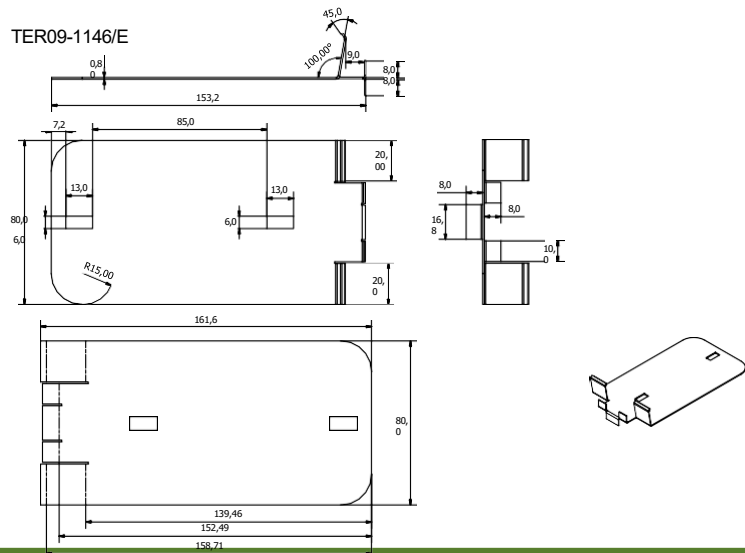

# STAINLESS STEEL SIDE TILE FINISHING BRACKETS

TER09-1146/D

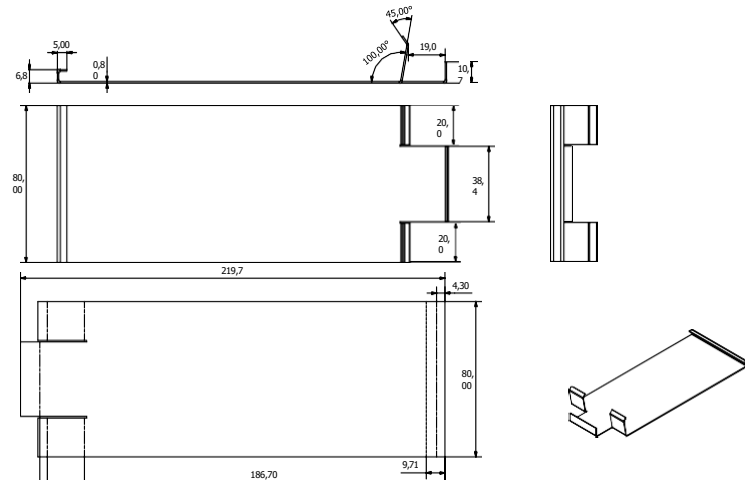

TER09-1146/F

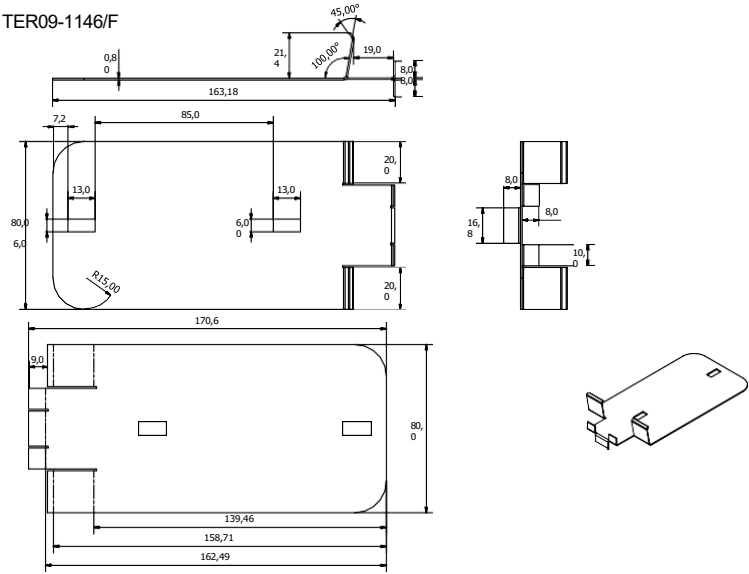

## 2. USE

Used when laying perimeter tiles with Dakota raised floor supports.

## 3. SPECIFICATION ITEMS

Entry	Description	Unit	Price
<b>Dak.D. TER09-1146/x</b>	Supply and installation of Bracket that allows, in the installation of floating floors, the finishing of the perimeter space in the absence of a side retaining wall. Specifically designed for use only with Dakota, Arkimede and Arkimede Nano floating supports. Made of stainless steel. Used for perimeter finishing in the absence of a retaining side wall, when laying raised floors with Arkimede supports.		
<b>Dak.D. TER09-1146/C</b>	10 mm sub-base.....	pc.	-
<b>Dak.D. TER09-1146/E</b>	10 mm plate.....	pc.	-
<b>Dak.D. TER09-1146/D</b>	20 mm sub-base.....	pc.	-
<b>Dak.D. TER09-1146/F</b>	20 mm plate.....	pc.	-